

Ruční kliky

Litina

SPECIFIKACE

Typy

- Typ **F**: s pevnou rukojetí
- Typ **D**: s otočnou rukojetí

Tělo

Litina (GG)

- práškově lakováno, barva černá, povrch s texturou
- náboj obrobený

Pevné rukojeti DIN 39 (viz. strana 565)

Pozinkovaná ocel, modrý pozink

Otočné rukojeti DIN 98 (viz. strana 579)

Pozinkovaná ocel, modrý pozink



INFORMACE

Otvory v náboji d1 H7 nejsou uvedeny v oficiálním listu norem.

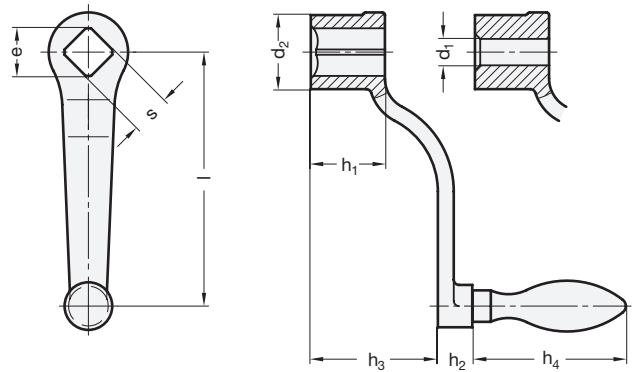

* Doplníte typ kliky (F nebo D)

F pevná rukojeť **D** otočná rukojeť

DIN 468

Označení	l	s H11	e min.	d1 H7	d2	h1	h2	h3 ≈	h4 ≈ Typ D	h4 ≈ Typ F	Ø Páka	⚖
DIN 468-63-V10-*	63	V 10	13.1	-	20	20	11	32	54.5	50	16	114
DIN 468-80-B8-*	80	-	13.1	B 8	24	24	13	38	61	56	18	195
DIN 468-80-V10-*	80	V 10	13.1	-	24	24	13	38	61	56	18	150
DIN 468-80-V12-*	80	V 12	13.1	-	24	24	13	38	61	56	18	173
DIN 468-100-B10-*	100	-	16.1	B 10	28	28	13	48	67	64	20	293
DIN 468-100-V12-*	100	V 12	16.1	-	28	28	13	48	67	64	20	281
DIN 468-100-V14-*	100	V 14	16.1	-	28	28	13	48	67	64	20	268
DIN 468-125-B10-*	125	-	18.1	B 10	34	34	14	55	76	72	22	463
DIN 468-125-V14-*	125	V 14	18.1	-	34	34	14	55	76	72	22	434
DIN 468-125-V17-*	125	V 17	18.1	-	34	34	14	55	76	72	22	413
DIN 468-160-B14-*	160	-	22.2	B 14	38	38	14	65	83	80	25	697
DIN 468-160-V17-*	160	V 17	22.2	-	38	38	14	65	83	80	25	650
DIN 468-160-V19-*	160	V 19	22.2	-	38	38	14	65	83	80	25	630
DIN 468-200-B17-*	200	-	25.2	B 17	44	44	21	78	96.5	90	28	1043
DIN 468-200-V19-*	200	V 19	25.2	-	44	44	21	78	96.5	90	28	999
DIN 468-200-V22-*	200	V 22	25.2	-	44	44	21	78	96.5	90	28	942
DIN 468-250-B17-*	250	-	28.2	B 17	48	48	21	90	105.5	100	32	1517
DIN 468-250-V22-*	250	V 22	28.2	-	48	48	21	90	105.5	100	32	1427
DIN 468-250-V24-*	250	V 24	28.2	-	48	48	21	90	105.5	100	32	1374
DIN 468-315-B20-*	315	-	32.2	B 20	54	54	26	105	117	112	36	2298
DIN 468-315-V24-*	315	V 24	32.2	-	54	54	26	105	117	112	36	2123
DIN 468-315-V27-*	315	V 27	32.2	-	54	54	26	105	117	112	36	2047

Váha pro typ F

